

6 5 4 3 2 1

F
E
D
C
B
A

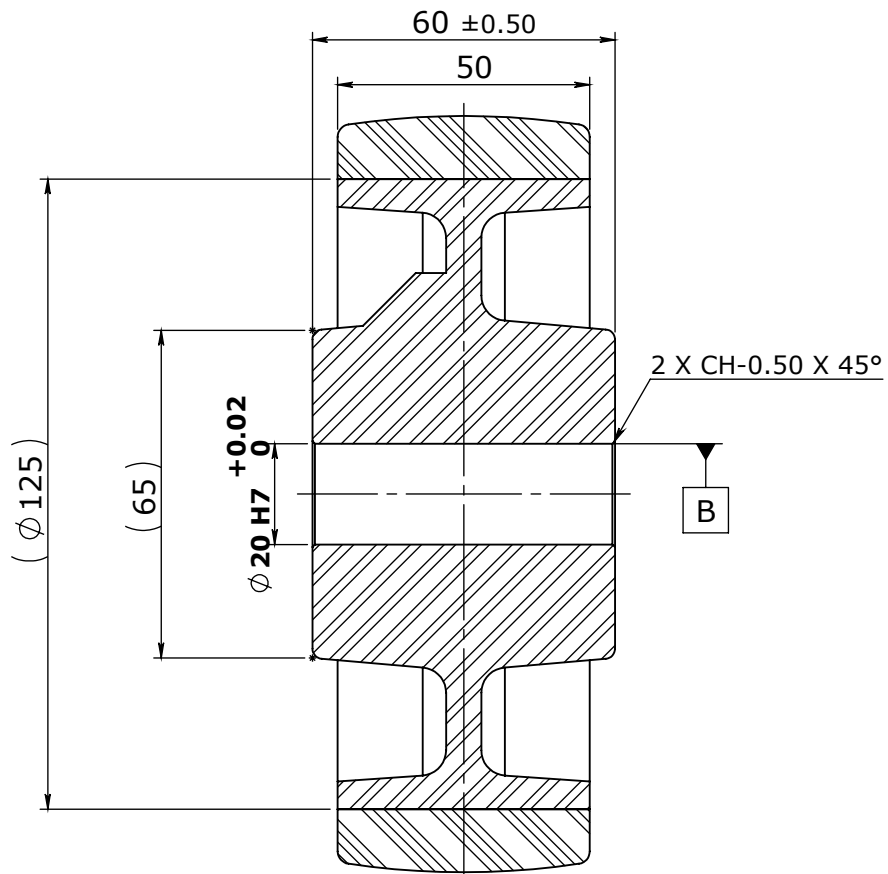

SECTION A-A

$\phi 150 \pm 0.75$
↑ 0.75 B

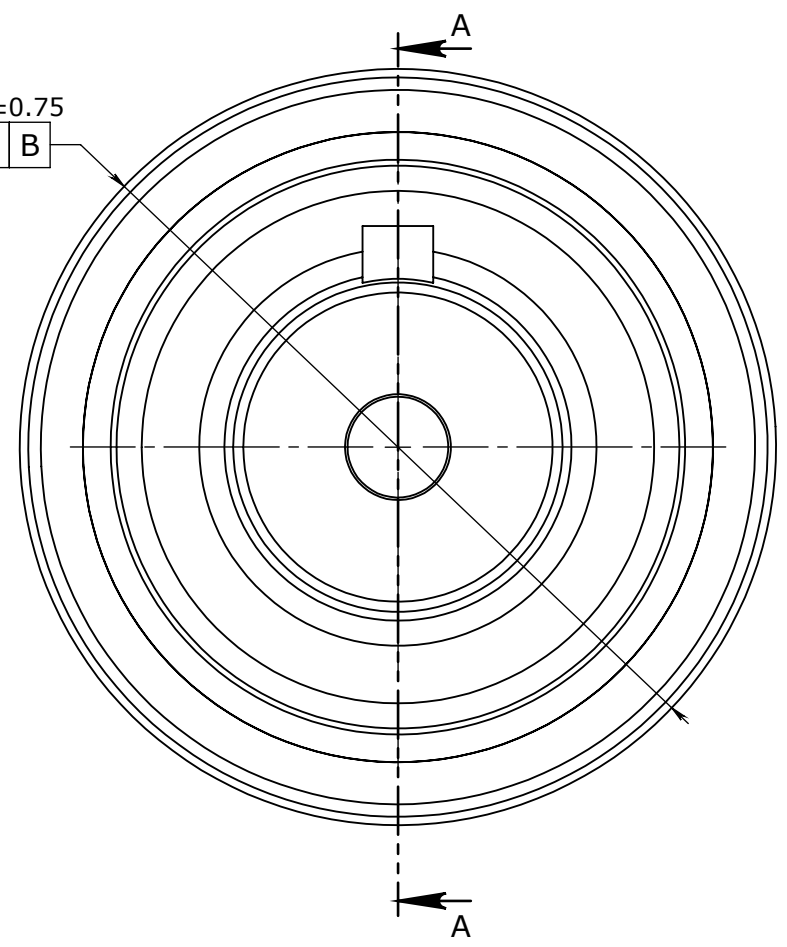

NOTE:-
 UNSPECIFIED TOLERANCES:-ISO:2768 MEDIUM
 ALL DIMENSIONS ARE IN MM
 TREAD MATERIAL-CAST POLYURETHANE
 HARDNESS:-SHORE A 93 +/- 3
 COLOR:- BROWN
 CORE:-CAST IRON
 CORE FINISH:-BLACK PAINT

DATE:	29-10-2025				
MATERIAL:					
QUANTITY:		DGN BY:	CHK BY:	VRFY BY:	APD BY:
SCALE:	NTS	VSG	RB	OPS	CS
REVISION:	00				
SHEET:	1/1				
REF.NO					
	ERP CODE	TITLE:			
	1304592	SAS-150X50-PB20			

6 5 4 3 2 1