

# LPA-GSPO 35K

Light duty swivel castor, with top plate fitting, heavy duty wheel made of compressed cast nylon

EAN 4047526119751  
 ID 760899  
 Customs tariff number 83022000



**Bracket:** LPA series

- pressed steel, zinc-plated, blue-passivated, Cr6-free
- double ball bearing in the swivel head
- strong central kingpin
- minimum swivel head play and smooth rolling characteristic and increased service life due to the special dynamic Blickle riveting process

**Wheel:** GSPO series

- high-quality cast nylon, reaction-injected, impact resistant, hardness 80 Shore D, colour natural beige

**Other features:**

- high chemical resistance to many aggressive substances
- reduced moisture absorption
- operating temperature: -20 °C to +80 °C, reduced load capacity over +35 °C
- consider the surface pressure on sensitive floors due to high point loads
- Test in compliance with DIN 12530 with extended breaks to avoid thermal overloading

**Technical data:**

Wheel Ø (D)	⊘	35 mm
Wheel width	∟	28 mm
Load capacity at 3 km/h	⊞	100 kg
Load capacity at 4 km/h	⊞	100 kg
Load capacity (static)	⊞	250 kg
Bearing type	⊙	ball bearing
Total height (H)	∅	52 mm
Plate size	⊞	60 x 60 mm
Bolt hole spacing	⊞	38 x 38 / 48 x 48 mm
Bolt hole Ø	⊞	6.2 mm
Offset (F)	⊞	15 mm
Temperature resistance min		-20 °C
Temperature resistance max		80 °C
Tread and tyre hardness		80 Shore D
Unit weight	⊞	0.2 kg
Non-marking		✓
Non-staining		✓
Antistatic	⊞	✗
Electrically conductive	⊞	✗
Corrosion-resistant		✗
Heat-resistant	⊞	✗
Tread hydrolysis-resistant		✗
Suitable for autoclaves		✗



**Tread and tyre hardness**



**Rolling resistance**



**Wear resistance**



**Operating noise / floor surface preservation**

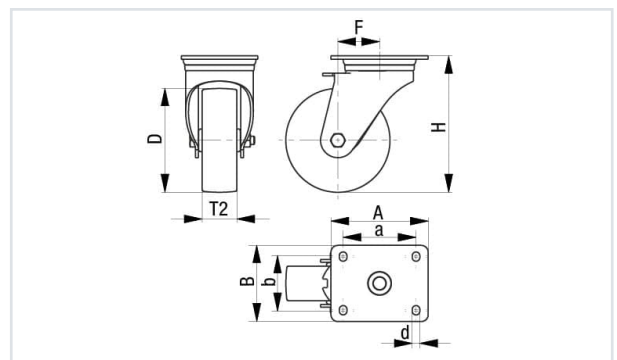
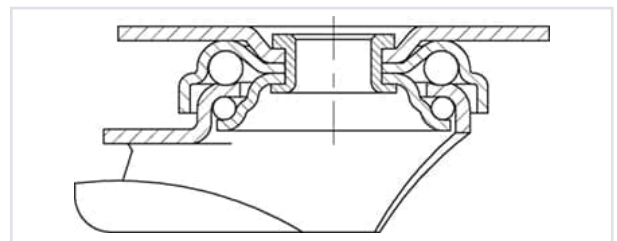

## Product references

